



## Why use Norfoam Insulated Paneling

Made Locally in North Queensland using *BlueScope Steel*

Norfoam's polystyrene core provides efficient, long-lasting insulation and comfort all year round – winter or summer

Norfoam's insulated panel is long-lasting and easy to clean finish

Simple Construction – No rafters, battens or trusses required

Colorbond® steel laminated to high performing polystyrene core provides strength and durability

Norfoam provides you with piece of mind offering a 5 year warranty on your panel.

Saves Money and Adds Value to your home

Strong & Durable

Versatile can be used for patios, enclosed extensions, carports and for a variety of other structures.

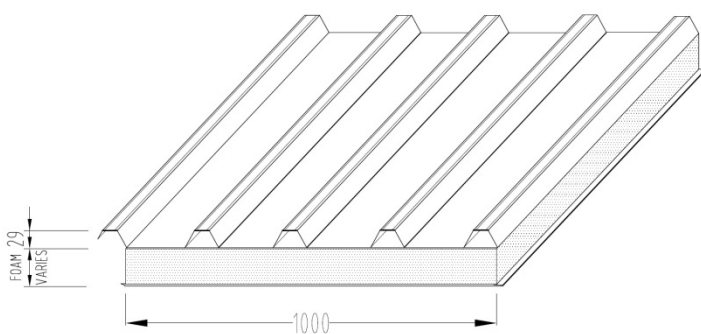

NORFOAM INSULATED PANEL (NORDECK)

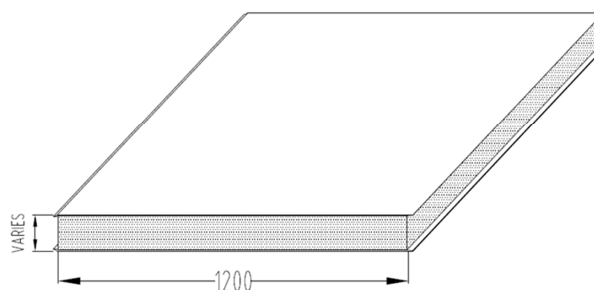

NORFOAM INSULATED PANEL (FLAT)

NOTE: This panel can come in a Ribbed/RIPPLE finish

